

Tous droits strictement reserves. Reproduction ou communication a des tiers interdite sous quelque forme que ce soit sans autorisation écrite du propriétaire. Propriete de c FCI. Droits de reproduction FCI.

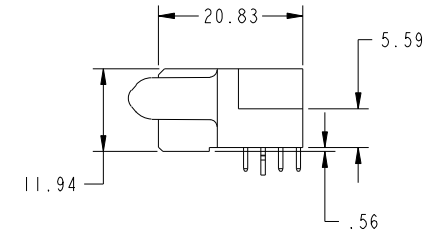

All rights strictly reserved. Reproduction or issue to third parties in any form whatever is not permitted without written authority from the proprietor. Property of FCI. Copyright FCI.

PRODUCT NO.	ROWS	SIGNAL						POWER						E1		
		E2	6	5	4	3	2	1	P7	P6	P5	P4	P3		P2	P1
51915-014_- NOTE:3	D C B A		H	H	H	H	H	H	PA	PA	PA	PA	PA	PA	PA	
		G	G	G	G	G	G	G								
		F	F	F	F	F	F	F								
		E	E	E	E	E	E									

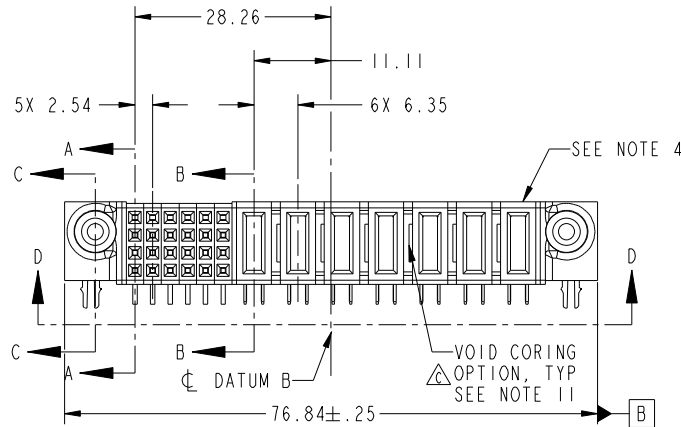

CODE	DIM "M" MATING LENGTH	CONTACT TYPE
E	[N/A]	SIGNAL
F	[N/A]	SIGNAL
G	[N/A]	SIGNAL
H	[N/A]	SIGNAL
PA	[1.07]	POWER
HA	[N/A]	HOLD-DOWN

mat'l code				SEE NOTE		tolerances unless otherwise specified		CUSTOMER		FCI	
ltr	ecn no.	dr	date	linear	0.X ± 0.5	projection	COPY		www.fciconnect.com		
A	V21339	TAB	08-15-02		0.XX ± 0.25		title		7P + 24S		
B	DG05-0355	CS	09/26/05	angles	0.XXX ± 0.10		RIGHT ANGLE SOLDER RECEPTACLE		product family PwrBlade code 213		
C	DG07-0498	JW	09/15/08		0° + 2°	scale	size		dwg no 51915-014 sheet 1 of 4		
				dr	T. BRUNGARD 08-15-02	1:1	A		cage code 22526		
				enrg	M. MOSTOLLER 08-15-02						
				chr	M. MOSTOLLER 08-15-02						
				appd	M. MOSTOLLER 08-15-02						
sheet index	revision sheet	C	C	C	C						
		1	2	3	4						

Pro/E

cage code 22526

Tous droits strictement reserves. Reproduction ou communication a des tiers interdite sous quelque forme que ce soit sans autorisation écrite du propriétaire. Propriete de c FCI. Droits de reproduction FCI.



All rights strictly reserved. Reproduction or issue to third parties in any form whatever is not permitted without written authority from the proprietor. Property of FCI. Copyright FCI.

PRODUCT NUMBER
51915-014--
NOTE: 3

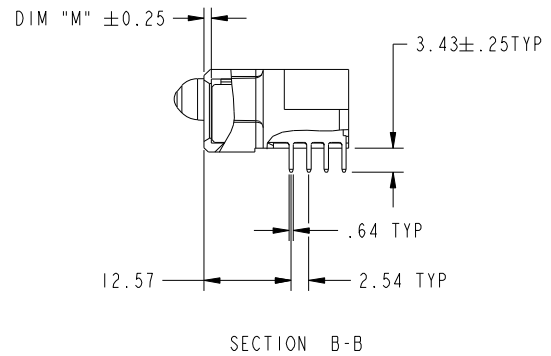
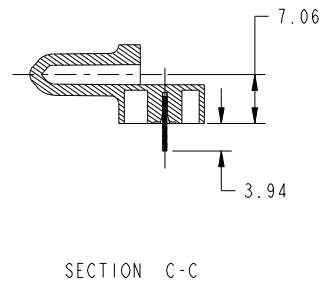
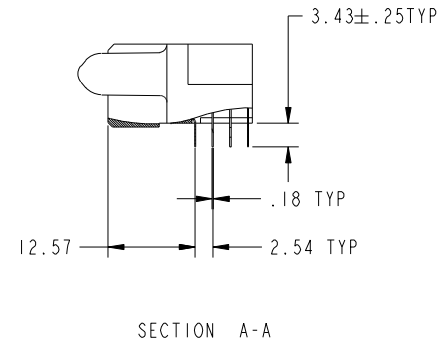
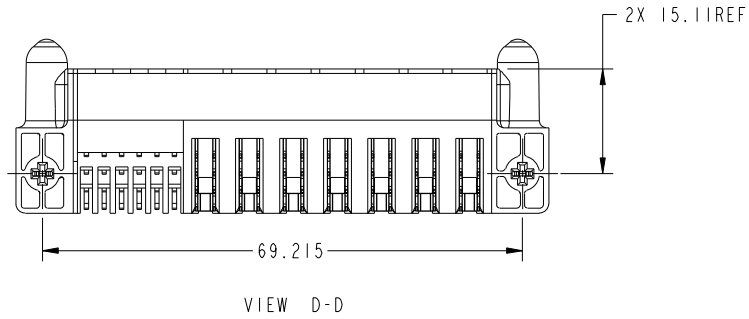

mat'l code		SEE NOTE		tolerances unless otherwise specified		CUSTOMER		www.fciconnect.com	
ltr	ecn no.	dr	date	linear	0.X ± 0.5	COPY		title	
C					0.XX ± 0.25	projection		7P + 24S	
				angles	0.XXX ± 0.10			RIGHT ANGLE SOLDER RECEPTACLE	
				dr	T. BRUNGARD 08-15-02	MIM		product family	PwrBlade
				enrg	M. MOSTOLLER 08-15-02			size	code
				chr	M. MOSTOLLER 08-15-02	scale		dwg no	213
				appd	M. MOSTOLLER 08-15-02	1:1		51915-014	sheet
sheet index	revision sheet								2

cage code 22526

Pro/E

Tous droits strictement reserves. Reproduction ou communication a des tiers interdite sous quelque forme que ce soit sans autorisation écrite du propriétaire. Propriete de c FCI. Droits de reproduction FCI.



All rights strictly reserved. Reproduction or issue to third parties in any form whatever is not permitted without written authority from the proprietor. Property of FCI. Copyright FCI.

PRODUCT NUMBER
51915-014_-
NOTE: 3

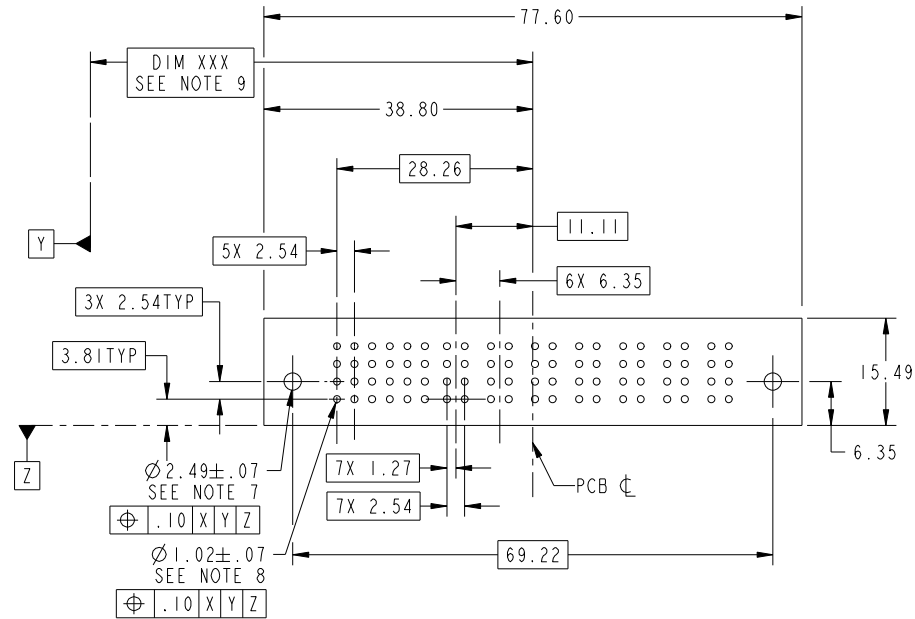

mat'l code				SEE NOTE		tolerances unless otherwise specified		CUSTOMER		FCI www.fciconnect.com	
ltr	ecn no.	dr	date	linear	0.X ±0.5		COPY		title 7P + 24S RIGHT ANGLE SOLDER RECEPTACLE		
C					0.XX ±0.25		projection				
					0.XXX ±0.10						
				angles	0° ±2°				product family PwrBlade code 213		
				dr	T. BRUNGARD	08-15-02	scale		size dwg no 51915-014 sheet 3		
				enrg	M. MOSTOLLER	08-15-02	1:1		A		
				chr	M. MOSTOLLER	08-15-02					
				appd	M. MOSTOLLER	08-15-02					
sheet index		revision sheet								cage code 22526	

Pro/E

cage code 22526

Tous droits strictement réservés. Reproduction ou communication a des tiers interdite sous quelque forme que ce soit sans autorisation écrite du propriétaire. Propriete de c FCI. Droits de reproduction FCI.



All rights strictly reserved. Reproduction or issue to third parties in any form whatever is not permitted without written authority from the proprietor. Property of FCI. Copyright FCI.

PRODUCT NUMBER
51915-014_- NOTE: 3

NOTES:

1. DIMENSIONS AND TOLERANCES ARE IN ACCORDANCE WITH ASME Y14.5M, 1994 UNLESS OTHERWISE SPECIFIED.

CONNECTORS NOTES:

② HOUSING MATERIAL: UL 94 V-0 GLASS FILLED HIGH TEMP THERMO PLASTIC
POWER CONTACT MATERIAL: COPPER ALLOY
SIGNAL PIN MATERIAL: COPPER ALLOY

③ PLATING:

△ SEE ITEM 5 & 6 PRINT 10064183 FOR PLATING SPEC OF 51915-014; 51915-014LF RESPECTIVELY

④ "MANUFACTURER" NAME, P/N, AND DATE CODE TO APPEAR ON THIS SURFACE.

⑤ PRODUCT SPECIFICATION GS-12-149.

PCB - NOTES:

⑥ ALL HOLE DIAMETERS ARE FINISHED HOLE SIZE.

7. HOLD DOWN THROUGH HOLES ARE UNPLATED.

8. $\varnothing 1.151 \pm 0.025$ DRILLED HOLES PLATED WITH 0.008 MIN SnPb OR Sn OVER 0.03 TO 0.08 Cu PLATING TO ACHIEVE $\varnothing 1.02 \pm 0.07$ HOLE.

9. "DIM XXX" TO BE DETERMINED BY THE CUSTOMER.

10. A △ SYMBOL WILL BE NEXT TO ANY DIMENSION, VIEW, OR NOTE WHICH HAS BEEN MODIFIED WITH THE CURRENT DRAWING REVISION.

11. THE VOID CORING IN BETWEEN POWER MODULES, SIGNAL MODULES AND END MODULES ARE OPTIONAL AND THE SHAPE MAY BE DIFFERENT FOR OPTIMIZING THE MOLDING PROCESS. THE VOID CORING WILL NOT EFFECT TO PRODUCT FUNCTION.

mat'l code		SEE NOTE		tolerances unless otherwise specified		CUSTOMER		FCI		www.fciconnect.com	
ltr	ecn no.	dr	date	linear	$0.X \pm 0.5$	COPY		title			
C					$0.XX \pm 0.25$	projection		7P + 24S			
				angles	$0.XXX \pm 0.10$			RIGHT ANGLE SOLDER RECEPTACLE			
				dr	T. BRUNGARD 08-15-02	MIM		product family		PwrBlade	code
				enrg	M. MOSTOLLER 08-15-02			size		dwg no	213
				chr	M. MOSTOLLER 08-15-02	scale		A		51915-014	sheet
				appd	M. MOSTOLLER 08-15-02	1:1				4	
sheet index	revision sheet										

cage code 22526

Pro/E